



TRANE®

*Cooling and Heating
Systems and Services*

Indoor liquid chiller

**CGWH Packaged Water-cooled
liquid chiller**

CCUH Condenserless liquid chiller

**Sizes: 115 - 120 - 125 - 225 - 230 - 235 -
240 - 250**



CG-PRC008-E4



Contents

Introduction	4
Features and benefits	5
Options description	9
Applications consideration	10
Control	15
Selection Procedures	21
Performances	23
General data	26
Hydraulic data	28
Sound performances	29
Units schematics	30



Introduction

The CGWH/CCUH chillers range equipped with Scroll compressors combines the latest technologies available to offer an optimum answer for today's air-conditioning and process cooling applications:

- Scroll compressor technology, with high performance, limited maintenance and longer life time design
- Latest generation of Trane controls, with user friendly graphical interface and integral auto-adaptive to guarantee maximum dependability
- High efficiency heat exchangers, allowing significant savings on operating cost
- Integrated hydraulic packages, to shorten installation and commissioning time.

Features and benefits

Industry leading performance and flexibility for design engineers

The next generation: designed for You

The third generation of the successful indoor Scroll compressor product range has several benefits over the previous design. Your suggestions led to the improvements we have incorporated, including:

- Higher full-load energy efficiency for lower operating and life-cycle costs
- CH530 controls, with touch-screen display and LonTalk[®] capability
- Less sensitivity to condenser-water temperatures, alleviating concerns based on start-up temperatures
- Lighter weight for easier and less expensive handling and installation.

Applications: Operation and control advantages for any application

The Scroll compressor technology, with fewer moving parts, less rotating mass and less internal friction, associated with CH530 and Adaptive Controls[™], allow the CGWH/CCUH range to be used in a wide variety of applications including:

- Comfort cooling: designed for reliability, energy efficiency, and system-design optimisation, whether the heat is rejected via an open cooling tower or a closed loop device (dry-cooler)
- Industrial process cooling: reliable operation with tight control of temperatures
- Ice/thermal storage
- Heat recovery
- Low-temperature process cooling.

System design and control: Greater application flexibility for increased savings

First-cost and operating cost minimising system-design concepts are catching on as their validity is proven through applications. These designs can provide lower equipment costs and lower operating costs than those possible with the traditional design methods and past chiller technologies. The concepts of the CGWH/CCUH range include:

- Heat exchangers with reduced water pressure drops and wider water flow/delta capability
- Thermal storage capability
- Variable primary (evaporator) chilled-water flow capability
- Series evaporator and/or condenser arrangements

The CGWH/CCUH range is designed for a wide range of applications and is especially suited for the dynamics of these system saving job designs. The dynamic benefits include:

- Efficient lift capability
- Tight temperature control.

CH530 controls mean that the CGWH/CCUH series chillers can maintain tight leaving-water temperature control in almost any application. These benefits fit especially well with the system design savings ideas listed above. As the compressor reaches the operating temperatures for the application, the controls, make sure you have total temperature control, even with chilled-water flow and/or load changes.

Features and benefits

Sound: Lower sound levels through compressor and chiller design

Trane has a proven track record of continuously improving the sound levels of water chillers. With the CGWH/CCUH range Trane has designed a fully hermetic cabinet design which minimises sound radiation in the neighbourhood of the unit. The space around the chiller can be utilised without requirement of additional sound insulation. Only the sound produced by the remote condenser fans can be perceived in the surrounding of the installation, the sound of compressor is attenuated by the building structure.

Minimised job time for contractors through design and testing

Ease of installation

- Footprint: Central to the design of any project is the operating envelope of the chiller. With this in mind, Trane builds the chillers to make the most efficient use of the available installation space. The compact CGWH/CCUH range chiller is an excellent choice for any retrofit or replacement job. It is smaller than most chillers it might replace, and easier to fit into existing buildings. All units fit through a standard single door.
- Weight: Furthermore, the decreased weight reduces the requirements for lifting, rigging, and installation. Installation time and effort are reduced when dealing with a significantly smaller and lighter unit.
- Commissioning: Water cooled units (CGWH) come from factory fully charged with refrigerant and oil, condenserless version (CCUH) with holding charge. Extensive factory testing helps ensure trouble-free start-up, resulting in lower installation costs and faster job completion.

The Integrated comfort system

The water-cooled CGWH/CCUH chiller, with the CH530, makes a powerful combination with the Trane Tracer Summit Building Management System to become part of a Trane Integrated Comfort system (ICS). An Integrated Comfort system is a building comfort system composed of Trane HVAC equipment, integral unit controllers, and building management. It is all designed and commissioned with Trane application expertise to provide comfort, efficiency, and reliability, as well as single-source warranty and service. Whether you are replacing a chiller or adding one to any centrally controlled plant, the Tracer CH530 chiller controller offers a wide range of interface options. Its ability to communicate with other systems using industry-standard control signals allows you to upgrade the control of your chiller plant regardless of your current control system.

Features and benefits

Single-source responsibility

A wide range of products designed for complete compatibility are available with the CGWH/CCUH scroll chillers. Your entire building comfort system can be completed using components from Trane.

The added value of applications expertise

You get a quality chiller, properly selected and applied in a properly designed system. That means a comfort system that works, the first time!

Reduced total life cycle operating cost for building owner.

Energy efficiency: Reduced annual operating expenses

The CGWH/CCUH chiller design has been optimized in order to achieve record efficiency levels. With the CH530 chiller control module, control over the chilled-water temperature is increased, simultaneously reducing annual operating costs. CGWH/CCUH chillers offer superior full-load performance and optimised part-load performance.

Reduced maintenance: Less time and money every year

The only recommended maintenance for a CGWH/CCUH chiller is an annual oil analysis. The hermetic design allows the compressor to be driven by a zero-maintenance motor. The installation of strainers upstream the evaporator and condenser (Option) eliminates the need for cleaning the heat exchangers tubes. The Adaptive Control™ microprocessor also helps reduce unnecessary maintenance by monitoring, protecting, and taking corrective action so that the chiller stays on-line when you need it the most. Service calls for nuisance trip-outs are virtually eliminated.

Reliability

Trane has designed the CGWH/CCUH chiller range to be a leader in reliability for all applications:

- Simple design with 64 percent fewer parts than equal capacity reciprocating compressor.
- Advanced microelectronics protect both compressor and motor from typical electrical fault conditions.
- Scroll compressors have less than a third the torque variations of a reciprocating compressor.
- Years of laboratory testing have optimised compressor and chiller systems reliability.
- Water-cooled scroll chillers are factory tested.

Comfort cooling: designed for reliability, energy efficiency, and system design optimisation

Most comfort-cooling applications consider reliability and energy efficiency above all else in the design requirements. With proven reliability and high chiller efficiency, the CGWH/CCUH chillers are perfectly suited for these applications.

Industrial process cooling / Low temperature process: Reliable operation with tight control of temperatures

The Trane CGWH/CCUH chillers have the proven reliability required to keep the process running, eliminating concerns for chiller and resulting process downtime. The chiller matches system requirements and rapidly adjusts to match the changes seen by most processes.



Features and benefits

Ice / thermal storage

The Trane CGWH/CCUH chillers can be used in partial or full thermal-storage applications because of their excellent compressor lift (operating temperature range) capability. High reliability and low maintenance means thermal storage applications are possible without a full-time operation/maintenance staff, and Trane Integrated Comfort System Controls can notify a computer or pager of any system issues.

Heat recovery

The Trane CGWH chillers compressor lift capabilities also play well in heat recovery, or just high-temperature condenser applications. Building energy saving initiatives such as using condenser water for reheat (dehumidification), preheating boiler water, and providing domestic hot water are compatible with its temperature capabilities.

Easy serviceability

Trane CGWH/CCUH chillers are designed with service personnel in mind. All major components are replaceable without complete unit disassembly. Plus, CH530 provides diagnostic capability to aid service personnel in analysing problems. Therefore, in case a problem does occur, the chiller can be up and running in a shorter period of time.

Options description

Hydraulic pump control:

- Single or dual pump contactor.

Hot water control

This option allows the control of the unit capacity based on the leaving condenser water temperature to provide heat recovery capability.

Phase protection device

Inhibits operation of chiller in case of phase reversal

Setpoint and temperature offset and display card

Allows to offset chilled water setpoint temperature based on either outside air, chilled water return or zone temperature and provides inlet/outlet condenser water temperature information.

High Efficiency Option

This option provides oversized heat exchangers to allow the unit to be more energy efficient.

Ice Making

The unit controls are factory set to handle ice making for thermal storage applications.

Communication Interface

Permits bi-directional communication to the Trane Integrated Comfort™ system and provides the LonMark® chiller profile input/outputs for use with a generic BAS (Building Automation System)

Low Noise Version

The unit is equipped with compressor sound jackets.

Pressure Gauges

A set of two pressure gauges per refrigerant circuit, one for low pressure and one for high pressure.

Applications consideration

Optimum performance of CGWH and CCUH units will be achieved only if proper application guidelines are followed.

Where the application varies from the guidelines presented, it should be reviewed with your local Trane sales engineer.

Unit sizing

Unit capacities are listed in the "Performance Data" section.

Intentionally oversizing a unit to assure adequate capacity is not recommended. Erratic system operation and excessive compressor cycling are often a direct result of an oversized unit. In addition, an oversized unit is usually more expensive to purchase, install and operate. If oversizing is desired, consider using two units.

Foundations

A special foundation is not required, provided the floor is flat, level and strong enough to support the unit's weight (see "General data" tables).

Table 1 - Standard Operating Enveloppe - See performance data for specific informations.

	CGWH R407C	CCUH R407C	
Min. leaving water temperature CDS	+20°C	+30°C	Min. Sat discharge temperature CDS (Dew point)
Max. leaving water temperature CDS	+50°C	+55°C	Max. Sat discharge temperature CDS (Dew point)
Min. leaving water temperature EVP	-12°C		
Max. leaving water temperature EVP	+12°C		

Limitation HP dans les tableaux = 24.5bar (Limitation Module 23 +/- 1 bar / Pressostat HP = 26 bar).

Limitation température de refoulement dans les tableaux = 130°C

Applications consideration

Ground isolators

4 isolators are supplied as standard. They will protect the unit from any contact with the ground.

Water drain

Ensure that near the unit is a large enough drain to evacuate the water when from the system emptying the unit for shutdown or repair.

Water connection

Water connections are threaded ISO R7 type, location and diameter are indicated on the submittals available on request.

Minimum water volume

The minimum recommended water volume depends on the type of application.

If necessary, provide a buffer tank. The control and safety devices are only certain to operate correctly if the system's water volume is sufficient.

Water treatment

The use of untreated or improperly treated water in chillers may result in scaling, erosion, corrosion or algae. It is recommended that the services of a qualified water-treatment specialist be obtained to determine what water treatment, if any, is advisable. Trane assumes no responsibility for the results of untreated, or improperly treated water

Flow rate limits

The minimum and maximum flow rates are indicated in the "Hydraulic data" charts section. Too low a flow rate may cause freezing of the evaporator. Too high a flow rate may cause erosion of the evaporator and very substantial pressure losses.

Table 2 - Minimum water loop

Sizes		115	120	125	225	230	235	240	250
CGWH Chillers Data	Cooling Capacity	51 kW	64 kW	77 kW	91 kW	103 kW	116 kW	127 kW	155 kW
	Biggest step	50%	60%	50%	42%	38%	34%	30%	25%
	Biggest step	26 kW	38 kW	39 kW	38 kW	39 kW	39 kW	38 kW	39 kW
	Minimum water loop for comfort	244 l	368 l	368 l	365 l	375 l	377 l	365 l	371 l

This table is estimated with
 - Condenser : Water 30°/35°C
 - Evaporator : Water 12°/7°C
 - Dead Band of 3°C

Sizes		115	120	125	225	230	235	240	250
CCUH Chillers Data	Cooling Capacity	51 kW	64 kW	77 kW	90 kW	102 kW	115 kW	127 kW	153 kW
	Biggest step	50%	60%	50%	42%	38%	34%	30%	25%
	Biggest step	26 kW	38 kW	38 kW	38 kW	39 kW	39 kW	38 kW	38 kW
	Minimum water loop for comfort	244 l	367 l	367 l	363 l	371 l	374 l	365 l	366 l

This table is estimated with
 - Condensing temp : 45°C with sub cooling 5°C
 - Evaporator : Water 12°/7°C
 - Dead Band of 3°C

Applications consideration

Split systems piping recommendations

Maximum distances and refrigerant line diameters between units must be checked according to the configuration and system operating conditions (Chilled water temperature and subcooling). Tables 3 to 7 provide the maximum acceptable height according to subcooling available and recommended diameters for discharge liquid lines.

Figure 1 - Installation configuration - CCUH and condenser at the same level

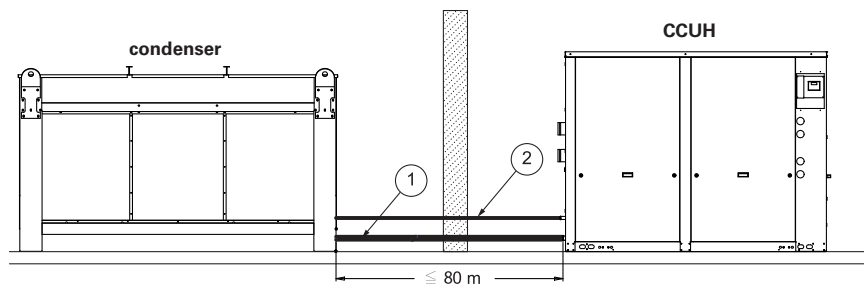

- 1: Discharge line
- 2: Liquid line

Figure 2 - Installation configuration - CCUH below condenser

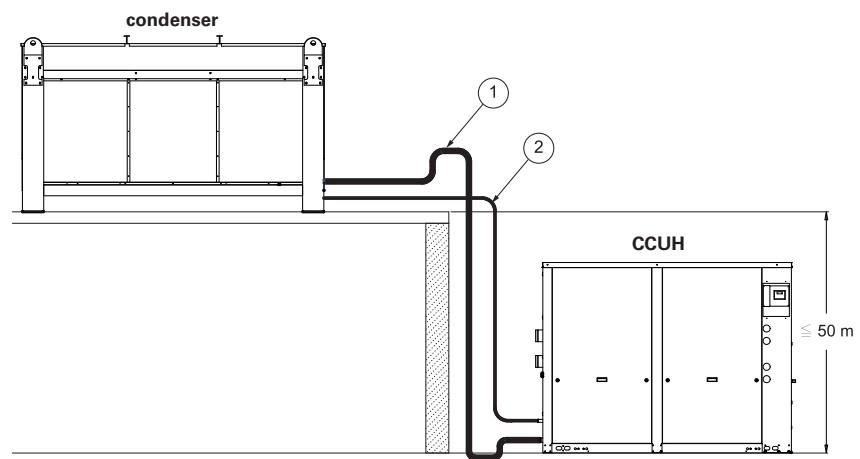

- 1: Discharge line
- 2: Liquid line

Applications consideration

Figure 3 - Installation configuration - CCUH above condenser

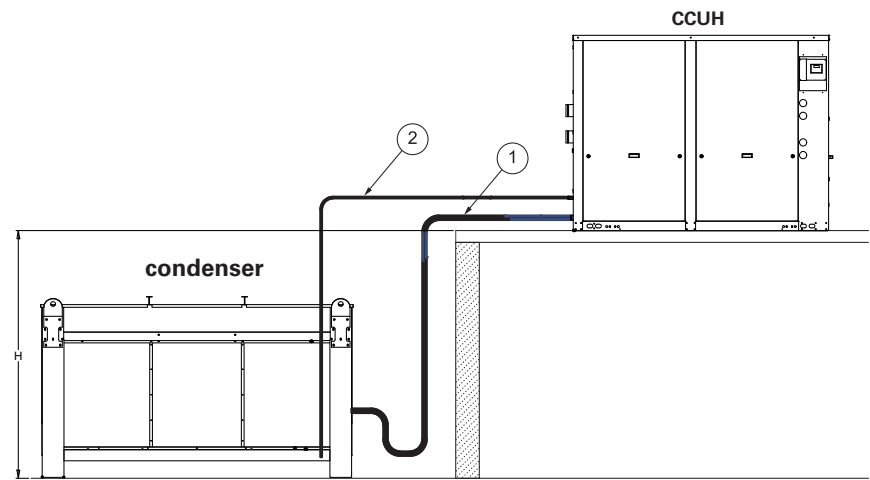

- 1: Discharge line
- 2: Liquid line

Table 3 - Maximum elevation (H) of CCUH above condenser

Subcooling °C	Condensing dew temperature °C			
	20°C	35°C	50°C	65°C
4°C	4 m	6 m	8 m	10 m
6°C	8 m	12 m	16 m	20 m
8°C	12 m	17 m	23 m	30 m
10°C	16 m	23 m	30 m	40 m
12°C	20 m	28 m	38 m	49 m

Table 4 - REQUIRED DISCHARGE LINE DIAMETER CCUH circuit 1 (for vertical risers)

Unit size	Leaving chilled water temperature													
	-12	-10	-8	-6	-4	-2	0	2	4	6	8	10	12	14
115				7/8"							1"1/8			
120				7/8"						1"1/8				1"3/8
125		7/8"					1"1/8					1"3/8		
225				7/8"							1"1/8			
230				7/8"						1"1/8		1"3/8		1"3/8
235		7/8"					1"1/8							
240				7/8"						1"1/8		1"3/8		1"3/8
250		7/8"					1"1/8							

Table 5 - REQUIRED DISCHARGE LINE DIAMETER CCUH circuit 2 (for vertical risers)

Unit size	Leaving chilled water temperature													
	-12	-10	-8	-6	-4	-2	0	2	4	6	8	10	12	14
225		7/8"								1"1/8				
230		7/8"								1"1/8				
235		7/8"								1"1/8				
240				7/8"						1"1/8				1"3/8
250		7/8"					1"1/8					1"3/8		



Applications consideration

Table 6 - REQUIRED LIQUID LINE DIAMETER CCUH circuit 1 (either vertical or horizontal)

Unit size	Leaving chilled water temperature													
	-12	-10	-8	-6	-4	-2	0	2	4	6	8	10	12	14
115			5/8"							7/8"				
120			5/8"					7/8"					1"1/8	
125		5/8"										1"1/8		
225			5/8"			7/8"				7/8"				
230			5/8"					7/8"					1"1/8	
235		5/8"				7/8"						1"1/8		
240			5/8"					7/8"					1"1/8	
250		5/8"				7/8"						1"1/8		

Table 7 - REQUIRED LIQUID LINE DIAMETER CCUH circuit 2 (either vertical or horizontal)

Unit size	Leaving chilled water temperature													
	-12	-10	-8	-6	-4	-2	0	2	4	6	8	10	12	14
225		5/8"						7/8"						
230		5/8"						7/8"						
235		5/8"						7/8"						
240			5/8"					7/8"					1"1/8	
250		5/8"				7/8"						1"1/8		

Control

Safety Controls

A centralized microcomputer offers a higher level of machine protection. Because the safety controls are smarter, they limit compressor operation in order to avoid compressor or evaporator failures, thereby minimizing nuisance shutdowns. Tracer™ Chiller Controls directly senses the control variables that govern the operation of the chiller: evaporator pressure, condenser pressure. When any one of these variables approaches a limit condition at which the unit may be damaged or shut down on a safety, Tracer Chiller Controls takes corrective action to avoid shutdown and keep the chiller operating. It does this through combined actions of compressor staging and pump staging. It has also the capability to control the remote condenser fan staging for condenserless unit (CCUH). Tracer Chiller Controls optimizes total chiller power consumption during normal operating conditions. During abnormal operating conditions, the microprocessor will continue to optimize chiller performance by taking the corrective action necessary to avoid shutdown. This keeps cooling capacity available until the problem can be solved. Whenever possible, the chiller is allowed to perform its function: make chilled water. In addition, microcomputer controls allow for more types of protection, like winter freeze protection; the safety controls help keep the building or process running and out of trouble.

Stand-alone controls

Interfacing to stand-alone units is very simple: only a remote auto/stop for scheduling is required for unit operation. Signals from the chilled-water pump contactor auxiliary, or a flow switch, are wired to the chilled-water flow interlock. Signals from a time clock or some other remote device are wired to the external auto/stop input.

Tracer™ Chiller Control human interfaces





Control

Standard Features External Auto/Stop

A job-site-provided contact closure will turn the unit on and off.

Chilled Waterflow Interlock

Unit is equipped with a water flow control, it will allow unit operation if a load exists. This feature will allow the unit to run in conjunction with the pump system.

External Interlock

A job-site-provided contact opening wired to this input will turn the unit off and require a manual reset of the unit microcomputer. This closure is typically triggered by a job-site-provided system such as a fire alarm.

Chilled Water Pump Control (Option)

Unit controls provide an output to control the chilled-water pump(s). One contact closure to the chiller is all that is required to initiate the chilled-water system.

Alarm Indication Contacts

Four factory-installed contacts with the following preset default assignments:

- Alarm
- Chiller running
- Maximum capacity
- Chiller limit.

Additional Features that May Be Added (require some optional factory-installed hardware)

- Ice-making card
- Tracer communication card
- Chilled water and remote current limit set point card (note: all wiring outside the unit is supplied by the contractor).

Control

Easy Interface to a Generic Building Management System

Controlling the Indoor CGWH/CCUH chillers with building management systems is state-of-the-art, yet simple with either:

- the LonTalk Communications Interface for Chillers (LCI-C)
- or Generic Building Management System Hardwire Points.

Simple Interface with Other Control Systems

Microcomputer controls afford simple interface with other control systems, such as time clocks, building automation systems, and ice storage systems. This means you have the flexibility to meet job requirements while not having to learn a complicated control system. This setup has the same standard features as a stand-alone water chiller, with the possibility of having additional optional features.

What are LonTalk, Echelon, and LonMark?

LonTalk is a communications protocol developed by the Echelon Corporation. The LonMark association develops control profiles using the LonTalk communication protocol. LonTalk is a unit level communications protocol, unlike BACNet used at the system level.

LonTalk Communications Interface for Chillers (LCI-C)

LonTalk Communications Interface for Chillers (LCI-C) provides a generic automation system with the LonMark chiller profile inputs/outputs. The inputs/outputs include both mandatory and optional network variables. Note: LonMark network variable names are in parentheses when different from chiller naming convention.

Chiller Inputs:

- Chiller Enable/Disable
- Chilled Liquid Setpoint (Cool or hot Setpoint)
- Ice Making (Chiller Mode)

Chiller Enable/Disable

Allows for chiller to be started or stopped depending on if certain operating conditions are met.

Chilled Liquid Setpoint

Allows for the external setting independent of the front panel setpoint to adjust the leaving water temperature setpoint.

Hot Liquid Setpoint

Allows for the external setting independent of the front panel setpoint to adjust the leaving water temperature setpoint from the condenser.

Ice Making

Provides interface with ice making control systems.

Control

Chiller Outputs:

- On/Off Active Setpoint
- Leaving Chilled Water Temperature
- Entering Chilled Water Temperature
 - Leaving Hot Water Temperature
 - Entering Hot Water Temperature
- Alarm Descriptor
- Chiller Status

On/Off

Indicates the current state of the chiller

Active Setpoint

Indicates the current value of the leaving water temperature setpoint

Leaving Chilled Water Temperature

Provides the current leaving water temperature

Entering Chilled Water Temperature

Provides the current entering water temperature.

Leaving Hot Water Temperature

(Optional feature)

Provides the current leaving water temperature from the condenser.

Entering Hot Water Temperature

(Optional feature)

Provides the current entering water temperature from the condenser.

Alarm Descriptor

Provides alarm messages based on predetermined criteria

Chiller Status

Indicates the running modes and states of the chiller, i.e. Running in alarm mode, chiller enabled, chiller being locally controlled, etc.

Generic Building Management System Hardwire Points

GBAS may be achieved via hardware input/output as well. The input/outputs are as follows:

Chiller hardware inputs include:

- Chiller enable/disable
- Circuit enable/disable
- External chilled water setpoint - (Optional feature)
- Ice making enable – (Optional feature)

Control

External Chilled Water Setpoint - (Optional feature)

Allows the external setting independent of the front panel setpoint by one of two means:

- a) 2-10 VDC input, or
- b) 4-20 mA input

Chiller hardware outputs include:

- Compressor running indication
- Alarm indication (Ckt 1/Ckt 2)
- Maximum capacity
- Ice making status

Alarm Indication Contacts

The unit provides three single-pole/double-throw contact closures to indicate:

- a) Compressor on/off status
- b) Compressor running at maximum capacity
- c) Failure has occurred (Ckt 1/Ckt 2)

These contact closures may be used to trigger job site supplied alarm lights or alarm bells.

Ice Making Control - (Optional feature)

Provides interface with ice making control systems.

Tracer Summit™ Controls – Interface with the Trane Integrated Comfort System (ICS)

Trane Chiller Plant Control

The Tracer Chiller Plant Manager building management system provides building automation and energy management functions through stand-alone control. The Chiller Plant Control is capable of monitoring and controlling your entire chiller plant system.

Application software available:

- Time-of-day scheduling
- Chiller sequencing
- Process control language
- Boolean processing
- Zone control
- Reports and logs
- Custom messages
- Run time and maintenance
- Trend log
- PID control loops

And of course, the Trane Chiller Plant Control can be used on a stand-alone basis or tied into a complete building automation system. When the water-cooled chiller is used in conjunction with a Trane Tracer Summit™ system, the unit can be monitored and controlled from a remote location. The water-cooled chiller can be controlled to fit into the overall building automation strategy by using time-of-day scheduling, timed override, demand limiting, and chiller sequencing. A building owner can completely monitor the water-cooled chiller from the Tracer system, since all of the monitoring information indicated on the microcomputer can be read on the unit controllers Tracer system display. In addition, all the powerful diagnostic information can be read back at the Tracer system.



Control

Best of all, this powerful capability comes over a single twisted pair of wires! Water-Cooled chillers can interface with many different external control systems, from simple stand-alone units to ice-making systems. Each unit requires a single-source, three-phase power supply.

A single twisted pair of wires tied directly between the CGWH/CCUH chillers and a Tracer Summit™ system provides control, monitoring, and diagnostic capabilities. Control functions include auto/stop, adjustment of leaving-water-temperature set point and control of ice-making mode. The Tracer system reads monitoring information such as entering- and leaving-evaporator-water temperatures and entering- and leaving-condenser-water temperatures and outdoor air temperature. Over 60 individual diagnostic codes can be read by the Tracer system. In addition, the Tracer system can provide sequencing control for up to 25 units on the same chilled-water loop. Pump sequencing control can be provided from the Tracer system. Tracer ICS is not available in conjunction with the external set point capability.

Required Options

Tracer Interface

Additional Options that May Be Used

Ice-Making Control

External Trane Devices Required

Tracer Summit™, Tracer 100 System or Tracer Chiller Plant Control

Ice-Making Systems Controls

An ice-making option may be ordered with the water-cooled chiller. The unit will have two operating modes, ice making and normal daytime cooling. In the ice making mode, the water-cooled chiller will operate at full compressor capacity until the return chilled-fluid temperature entering the evaporator meets the ice making set point. Two input signals are required to the water-cooled chiller for the ice-making option. The first is an auto/stop signal for scheduling, and the second is required to switch the unit between the ice-making mode and normal daytime operation. The signals are provided by a remote job site building-automation device such as a time clock or a manual switch. In addition, the signals may be provided over the twisted wire pair from a Tracer™ system, or a LonTalk Communication Interface but will require the communication boards provided with the Ice Making Control Option.

Additional Options That May Be Used

- Failure Indication Contacts Communications Interface (For Tracer Systems)
- Chilled-Water Temperature Reset

Selection Procedures

The performance examples, on the following pages provide performance information at various capacities for the most common conditions.

The stated cooling capacities are based on:

Table 8 - Cooling capacities conditions

	Evaporator Δt (°C)	Condenser Δt (°C)	Fouling factor (m ² /K/kW)
CGWH Water cooled chillers	5	5	0.0044
CCUH Condenserless chillers	5	-	0.0044

The capacity ratings are applicable to a temperature drop within 4 to 8°C except as limited by the minimum or maximum water-flow rates as indicated by the heat exchanger's hydraulic resistance tables. If a different fouling factor is used, the unit capacity will vary. For conditions that are not directly tabulated, direct interpolation may be used. Extrapolation is not permitted.

Watercooled units: CGWH

To determine, the cooling capacity and the power input the following information is needed:

- the required cooling capacity
- the evaporator leaving water temperature
- the condenser leaving water temperature

Unit power input (P.I.), heat rejected by condenser, evaporator and condenser waterflow rates and associated pressure drops are given in the performance table.

Selection example:

Cooling capacity required (Cap):
100 kW

Evaporator leaving water

temperature (ELWT): 7°C

Condenser leaving water

temperature (CLWT): 40°C

By using the selection table it can be determined that the CGWH 230 gives a cooling capacity (cap) of 99.9 kW and a power input (P.I.) of 31.6 kW.

Selection Procedures

Condenserless units: CCUH

To determine the cooling capacity and the power input, the following information is needed:

- the required cooling capacity
- the outlet evaporator temperature
- the saturated condensing temperature

Unit power input, evaporator waterflow rates and pressure drop are given in the performance table.

Selection example:

Cooling capacity required (Cap):
100 kW

Evaporator leaving water
temperature (ELWT): 5°C

Saturated condensing temperature
(SCT): 50°C

By using the selection table it can be determined that the CCUH 235 Standard gives a cooling capacity (cap) of 104.0 kW and a power input (P.I.) of 37.1 kW.

Performances

Table 9 - Correction factors to apply when glycol is used in water loops

Fluid Type	Glycol Concentration		Performance		Evaporator		Condenser	
	Evaporator	Condenser	F-CC	F-PI	F-FLEVP	F-PDEVP	F-FLCDS	F-PDCDS
Water only	0%	0%	1.00	1.00	1.00	1.00	1.00	1.00
	10%	0%	0.99	1.00	1.02	1.02	1.00	1.00
	20%	0%	0.98	1.00	1.05	1.06	1.00	1.00
Ethylene Glycol	30%	0%	0.97	1.00	1.10	1.10	1.00	1.00
	0%	10%	1.00	1.00	1.00	1.00	1.02	1.05
	0%	20%	1.00	1.01	1.00	1.00	1.04	1.09
	0%	30%	1.00	1.02	1.00	1.00	1.08	1.14
	10%	0%	0.99	1.00	1.01	1.05	1.00	1.01
	20%	0%	0.97	1.00	1.03	1.10	1.00	1.00
Mono-Propylene Glycol	30%	0%	0.96	1.00	1.05	1.17	1.00	1.01
	0%	10%	1.00	1.01	1.00	1.00	1.01	1.06
	0%	20%	1.00	1.01	1.00	1.00	1.02	1.13
	0%	30%	0.99	1.02	1.00	1.00	1.05	1.21

The correction factors found in Table 5 can be applied as follows:

- 1) **Cooling capacity** with glycol [kW] = **F-CC** x Cooling capacity water [kW] (found in tables 10 and 11)
- 2) **Power Input** with glycol [kW] = **F-PI** x Power Input water [kW] (found in tables 10 and 11)
- 3) **Water Flow Evaporator** with glycol [Litres/sec] = **F-FLEVP** x Cooling capacity with glycol [kW] x 0.239 x (1 / Delta T Evaporator [°C])
- 4) **Water Pressure drop Evaporator** with glycol [kPa] = **F-PDEVP** x Water Pressure drop Evaporator water [kPa] (found in figure 4)

CGWH Only:

- 5) **Water Flow Condenser** with glycol [Litres/sec] = **F-FLCDS** x (Cooling capacity with glycol [kW] + Power input with glycol [kW]) x 0.239 x (1 / Delta T Condenser [°C])
- 6) **Water Pressure drop Condenser** with glycol [kPa] = **F-PDCDS** x Water Pressure drop Condenser water [kPa] (found in figure 5)

In case of application with negative temperature at the evaporator, combination of simultaneous usage of glycol both in evaporator and condenser, or usage of another type of fluid: please contact your local Trane sales representative

Performances

Table 10 - Selection table CGWH/R407C

		Leaving Water Temp. Condenser (°C) (Delta T° 5K)											
		25 °C		30 °C		35 °C		40 °C		45 °C		50 °C	
		Leaving water temp. Evaporator (°C)	Cooling cap (kW)	Power input (kW)	Cooling cap (kW)	Power input (kW)	Cooling cap (kW)	Power input (kW)	Cooling cap (kW)	Power input (kW)	Cooling cap (kW)	Power input (kW)	Cooling cap (kW)
CGWH 115 - STD / R407C	5.0	53.4	11.2	51.3	12.4	49.0	13.8	46.4	15.6	43.8	17.6	40.9	19.9
	7.0	56.7	11.3	54.5	12.5	52.1	13.9	49.5	15.7	46.6	17.8	43.6	20.1
	9.0	60.0	11.3	57.7	12.5	55.2	14.0	52.5	15.8	49.5	17.9	46.3	20.3
CGWH 120 - STD / R407C	5.0	66.9	14.1	64.2	15.7	61.4	17.5	58.3	19.7	55.0	22.2	51.5	25.0
	7.0	71.0	14.3	68.3	15.8	65.2	17.7	62.0	19.9	58.5	22.4	54.8	25.2
	9.0	75.2	14.4	72.3	15.9	69.2	17.8	65.7	20.0	62.1	22.6	58.2	25.4
CGWH 125 - STD / R407C	5.0	80.4	17.1	77.2	19.0	73.8	21.2	70.2	23.8	66.2	26.8	62.1	30.1
	7.0	85.2	17.2	81.9	19.1	78.4	21.4	74.5	24.0	70.4	27.1	66.0	30.4
	9.0	90.3	17.4	86.8	19.3	83.0	21.6	78.9	24.2	74.6	27.3	70.0	30.6
CGWH 225 - STD / R407C	5.0	94.9	19.6	91.2	21.7	87.1	24.2	82.7	27.3	78.0	30.8	73.0	34.7
	7.0	100.8	19.7	96.8	21.8	92.6	24.4	88.0	27.6	83.0	31.1	77.7	35.1
	9.0	106.8	19.9	102.6	22.0	98.1	24.6	93.3	27.8	88.1	31.4	82.5	35.4
CGWH 230 - STD / R407C	5.0	107.9	22.5	103.5	24.9	99.0	27.9	94.1	31.3	88.8	35.2	83.1	39.6
	7.0	114.4	22.6	110.0	25.1	105.1	28.1	99.9	31.6	94.3	35.5	88.4	39.9
	9.0	121.0	22.8	116.3	25.3	111.3	28.4	105.9	31.8	99.9	35.8	93.7	40.3
CGWH 235 - STD / R407C	5.0	121.1	25.2	116.4	28.0	111.3	31.2	105.8	35.0	99.9	39.3	93.7	44.2
	7.0	128.4	25.4	123.4	28.2	118.0	31.5	112.2	35.3	106.1	39.7	99.5	44.6
	9.0	135.7	25.6	130.4	28.5	124.8	31.8	118.7	35.7	112.2	40.0	105.4	45.1
CGWH 240 - STD / R407C	5.0	134.1	28.2	128.8	31.3	123.0	34.9	116.8	39.2	110.2	44.3	103.1	49.9
	7.0	142.0	28.4	136.4	31.5	130.4	35.2	123.8	39.6	116.9	44.7	109.5	50.3
	9.0	150.0	28.6	144.2	31.7	137.8	35.5	131.0	39.9	123.6	45.1	115.8	50.7
CGWH 250 - STD / R407C	5.0	162.8	33.8	156.3	37.4	149.4	41.7	141.9	46.9	134.0	52.6	125.7	59.1
	7.0	172.0	34.0	165.2	37.7	157.9	42.1	150.2	47.3	141.8	53.1	133.0	59.6
	9.0	181.0	34.3	174.0	38.0	166.4	42.4	158.2	47.7	149.5	53.6	140.3	60.1

Performances

Table 11 - Selection table CCUH/R407H

		Saturated discharge temperature subcooling 5K, superheating 6K											
		30 °C		35 °C		40 °C		45 °C		50 °C		55 °C	
Leaving water temp. Evaporator (°C)		Cooling	Power	Cooling	Power	Cooling	Power	Cooling	Power	Cooling	Power	Cooling	Power
		cap (kW)	input (kW)	cap (kW)	input (kW)	cap (kW)	input (kW)	cap (kW)	input (kW)	cap (kW)	input (kW)	cap (kW)	input (kW)
CCUH 115 - STD / R407C	5.0	55.2	10.6	53.2	11.5	51.0	12.8	48.6	14.4	46.1	16.2	43.3	18.4
	7.0	58.7	10.6	56.6	11.5	54.4	12.8	51.9	14.4	49.2	16.2	46.3	18.4
	9.0	62.3	10.6	60.2	11.5	57.8	12.8	55.3	14.3	52.5	16.2	49.4	18.4
CCUH 120 - STD / R407C	5.0	69.2	13.3	66.7	14.6	64.0	16.2	61.0	18.2	57.9	20.5	54.5	23.1
	7.0	73.6	13.3	71.0	14.6	68.2	16.2	65.1	18.2	61.8	20.5	58.2	23.1
	9.0	78.1	13.3	75.4	14.6	72.4	16.2	69.3	18.2	65.8	20.5	62.1	23.1
CCUH 125 - STD / R407C	5.0	83.1	16.1	80.1	17.7	76.9	19.7	73.4	22.0	69.6	24.7	65.6	27.8
	7.0	88.4	16.1	85.3	17.7	81.9	19.7	78.2	22.0	74.3	24.8	70.1	27.8
	9.0	93.7	16.1	90.5	17.7	86.9	19.7	83.1	22.1	79.0	24.8	74.6	27.9
CCUH 225 - STD / R407C	5.0	97.9	18.6	94.4	20.4	90.5	22.7	86.3	25.4	81.8	28.6	76.9	32.3
	7.0	104.2	18.6	100.5	20.4	96.5	22.6	92.1	25.4	87.3	28.6	82.2	32.3
	9.0	110.6	18.6	106.8	20.4	102.6	22.6	98.0	25.4	93.0	28.6	87.7	32.3
CCUH 230 - STD / R407C	5.0	111.2	21.4	107.1	23.5	102.7	26.1	98.0	29.2	92.9	32.9	87.4	37.0
	7.0	118.2	21.4	114.0	23.5	109.4	26.1	104.4	29.2	99.1	32.9	93.3	37.0
	9.0	125.3	21.4	120.9	23.5	116.1	26.1	110.9	29.2	105.4	32.9	99.4	37.0
CCUH 235 - STD / R407C	5.0	124.6	24.1	120.0	26.6	115.1	29.5	109.7	33.0	104.0	37.1	97.9	41.7
	7.0	132.3	24.2	127.6	26.6	122.4	29.5	116.8	33.1	110.9	37.1	104.5	41.7
	9.0	140.1	24.2	135.1	26.6	129.8	29.6	124.0	33.1	117.7	37.2	111.0	41.8
CCUH 240 - STD / R407C	5.0	138.6	26.7	133.5	29.2	128.0	32.5	122.1	36.4	115.7	41.0	108.9	46.2
	7.0	147.1	26.7	141.9	29.3	136.1	32.5	129.9	36.4	123.3	41.0	116.1	46.2
	9.0	155.7	26.7	150.2	29.3	144.2	32.5	137.8	36.4	130.8	41.0	123.4	46.2
CCUH 250 - STD / R407C	5.0	167.5	32.2	161.3	35.4	154.7	39.4	147.5	44.0	139.8	49.5	131.6	55.6
	7.0	177.4	32.2	171.0	35.4	164.0	39.4	156.5	44.1	148.5	49.5	139.9	55.7
	9.0	187.2	32.3	180.5	35.5	173.3	39.4	165.4	44.1	157.1	49.5	148.1	55.7

General data

Table 12 - R407C Refrigerant

		CGWH 115 R407C	CGWH 120 R407C	CGWH 125 R407C	CGWH 225 R407C	CGWH 230 R407C	CGWH 235 R407C	CGWH 240 R407C	CGWH 250 R407C
Eurovent Performances (1)									
Net Cooling Capacity	(kW)	52.1	65.4	78.5	92.5	105	118	130	158
Total Power input in cooling	(kW)	14.9	18.8	22.7	25.1	29.8	33.4	37.6	45.1
Evaporator water pressure drop	(kPa)	39	39	39	45	50	50	60	62
Condenser water pressure drop	(kPa)	62	63	64	71	79	78	94	95
Main Power supply	(V/Ph/Hz)	400/3/50							
Sound Power Level	(dB(A))	75	81	83	82	84	85	84	86
Units Amps									
Nominal (4)	(A)	35.4	44.3	53.2	62	70.9	79.8	88.6	106.4
Start-up Amps	(A)	137	192	201	209	218	227	236	254
Max supply cable size	(mm ²)	16	35	35	35	50	50	95	95
Compressor									
Number		2	2	2	3	3	3	4	4
Type		Scroll							
Model		10T+10T	10T+15T	2x15T	2x10T+15T	10T+2x15T	3x15T	2x(10T+15T)	4x15T
Number of speeds		1	1	1	1	1	1	1	1
Number of motors		1	1	1	1	1	1	1	1
Rated Amps (2)(4)	(A)	30	42	50	55	65	75	84	101
Locked rotor Amps (2)	(A)	120	175	175	175	175	175	175	175
Motor RPM	(rpm)	2900	2900	2900	2900	2900	2900	2900	2900
Sump Heater	(W)	10T compressor = 100W; 15T compressor = 160W							
Evaporator									
Number		1	1	1	1	1	1	1	1
Type		Braze plate							
Water volume (total)	(l)	4.7	5.9	7.0	8.9	10.3	12.3	12.3	16.1
Antifreeze Heater	(W)	-	-	-	-	-	-	-	-
Evaporator Water Connections									
Type		ISO R7 - Male							
Diameter		1"1/2	1"1/2	1"1/2	2"	2"	2"1/2	2"1/2	2"1/2
Condenser									
Number		1	1	1	1	1	1	1	1
Type		Braze plate	Braze plate	Braze plate	Braze plate	Braze plate	Braze plate	Braze plate	Braze plate
Water volume (total)	(l)	4.7	5.9	7.0	8.9	10.3	12.3	12.3	16.1
Antifreeze Heater	(W)	-	-	-	-	-	-	-	-
Condenser Water Connections									
Type ISO R7		Male	Male	Male	Male	Male	Male	Male	Male
Diameter		1"1/2	1"1/2	1"1/2	2"	2"	2"	2"1/2	2"1/2
Dimensions									
Height	(mm)	1545	1545	1545	1545	1545	1545	1545	1545
Length	(mm)	1001	1001	1001	2002	2002	2002	2002	2002
Width	(mm)	800	800	800	800	800	800	800	800
Weight uncrated	(kg)	389	416	443	626	655	689	757	815
Weight crated	(kg)	405	432	459	657	686	710	788	846
System Data									
Refrigerant circuit		1	1	1	2	2	2	2	2
Refrigerant Charge (3)									
Circuit A	(kg)	5	7	9	5	7	9	7	9
Circuit B	(kg)	-	-	5	5	5	7	9	-

(1) at Eurovent Conditions (Evap 12°C/7°C - Cond. 45°C - SC 5K)

(2) per motor

(3) per circuit

(4) 5°C sat suction temp. - 60°C sat discharge temp.

General data

Table 13 - R407C Refrigerant

		CCUH 115 R407C	CCUH 120 R407C	CCUH 125 R407C	CCUH 225 R407C	CCUH 230 R407C	CCUH 235 R407C	CCUH 240 R407C	CCUH 250 R407C
Eurovent Performances (1)									
Net Cooling Capacity	(kW)	52.0	65.2	78.3	92.2	104.0	117.3	129.5	156.1
Total Power input in cooling	(kW)	15.0	18.8	22.7	26.1	30.1	34	37.6	45.5
Evaporator water pressure drop	(kPa)	38	38	38	44	49	49	59	60
Main Power supply	(V/Ph/Hz)	400/3/50							
Sound Power Level	(dB(A))	75	81	83	82	84	85	84	86
Units Amps									
Nominal (4)	(A)	35.4	44.3	53.2	62	70.9	79.8	88.6	106.4
Start-up Amps	(A)	137	192	201	209	218	227	236	254
Recommended Fuse Size (Am)	(A)	Depends on installation							
Max supply cable size	(mm ²)	16	35	35	35	50	50	95	95
Max. Wire Length	(m)	Depends on installation							
Compressor									
Number		2	2	2	3	3	3	4	4
Type		Scroll							
Model		10T+10T	10T+15T	2x15T	2x10T+15T	10T+2x15T	3x15T	2x(10T+15T)	4x15T
Speeds number		1	1	1	1	1	1	1	1
Motors Number		1	1	1	1	1	1	1	1
Rated Amps (2)(4)	(A)	30	42	50	55	65	75	84	101
Locked rotor Amps (2)	(A)	120	175	175	175	175	175	175	175
Motor RPM	(rpm)	2900	2900	2900	2900	2900	2900	2900	2900
Sump Heater (2)	(W)	50W - 400V							
Evaporator									
Number		1	1	1	1	1	1	1	1
Type		Brazed plate							
Water volume (total)	(l)	4.7	5.9	7	8.9	10.3	12.3	12.3	16.1
Antifreeze Heater	(W)	-	-	-	-	-	-	-	-
Evaporator Water Connections									
Type		ISO R7 - Male							
Diameter		1 ½"	1 ½"	1 ½"	2"	2"	2 ½"	2 ½"	2 ½"
Discharge and liquid connections									
Type		Brazed - Female							
Discharge connection		1 1/8" ODF	1 3/8" ODF	1 3/8" ODF	1 1/8" ODF	1 3/8" ODF	1 3/8" ODF	1 3/8" ODF	1 3/8" ODF
Liquid connection		7/8" ODF	7/8" ODF	7/8" ODF	7/8" ODF	7/8" ODF	7/8" ODF	7/8" ODF	7/8" ODF
Dimensions									
Height	(mm)	1545	1545	1545	1545	1545	1545	1545	1545
Length	(mm)	1001	1001	1001	2002	2002	2002	2002	2002
Width	(mm)	800	800	800	800	800	800	800	800
Weight uncrated	(kg)	389	416	443	626	655	689	757	815
Weight crated	(kg)	405	432	459	657	686	710	788	846
System Data									
Refrigerant circuit		1	1	1	2	2	2	2	2

(1) at Eurovent Conditions (Evap 12°C/7°C - Cond. 45°C - SC 5K)

(2) per motor

(3) per circuit

(4) 5°C sat suction temp. - 60°C sat discharge temp.

Hydraulic data

Figure 4 - Evaporator water pressure drop

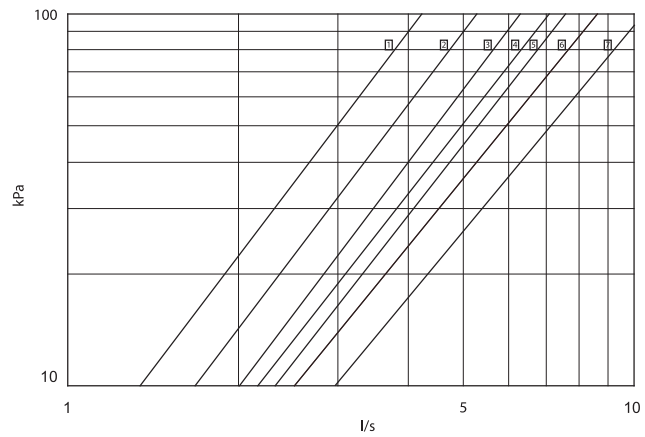

- 1 CGWH - CCUH 115
- 2 CGWH - CCUH 120
- 3 CGWH - CCUH 125
- 4 CGWH - CCUH 225
- 5 CGWH - CCUH 230
- 6 CGWH - CCUH 235 / 240
- 7 CGWH - CCUH 250

Figure 5 - Condenser water pressure drop

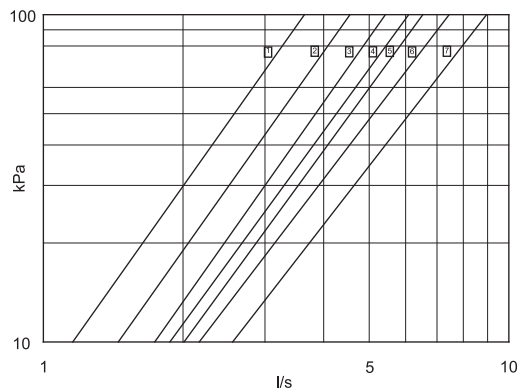

- 1 CGWH 115
- 2 CGWH 120
- 3 CGWH 125
- 4 CGWH 225
- 5 CGWH 230
- 6 CGWH 235 / 240
- 7 CGWH 250

Sound performances

Table 14 - Sound spectrum

CGWH & CCUH - Sound Data									
Size	63Hz	125Hz	250Hz	500Hz	1000Hz	2000Hz	4000Hz	8000Hz	dB(A)
115	81	63	58	74	67	70	59	49	75
120	85	62	64	77	73	72	67	57	79
125	87	62	67	79	76	73	69	59	81
225	92	68	67	77	75	74	69	60	80
230	94	68	70	79	77	75	71	62	82
235	95	67	71	80	78	76	73	64	83
240	95	63	68	77	78	75	69	59	82
250	97	63	70	79	80	77	71	61	84

Notes on sound power levels:

Sound power levels determined in accordance with ISO 3746-1996 for the overall sound power level in dBA.
 The sound levels given by octave band are for information only.
 - Reference source 1 pW.
 - Sound power levels are valid under free field conditions only, on a reflecting surface (directivity = 2) on all sides of the unit, for + 35°C ambient maximum.
 The compressor sound attenuating jackets permit to gain 3dBA.

Units schematics

Figure 6 - CGWH refrigerant flow chart

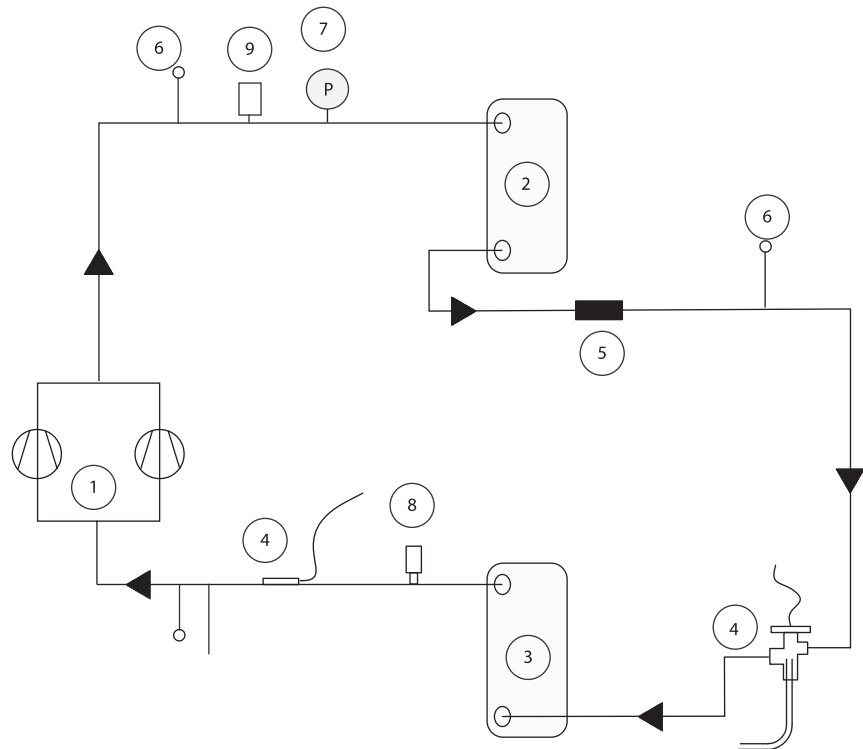

- 1: Compressor
- 2: Brazed plate condenser
- 3: Brazed plate evaporator
- 4: Expansion valve (Bulb+Balance port)
- 5: Filter dryer
- 6: Schraeder
- 7: High pressure switch
- 8: Low pressure transducer
- 9: High pressure transducer

Units schematics

Figure 7 – CCUH refrigerant flow chart

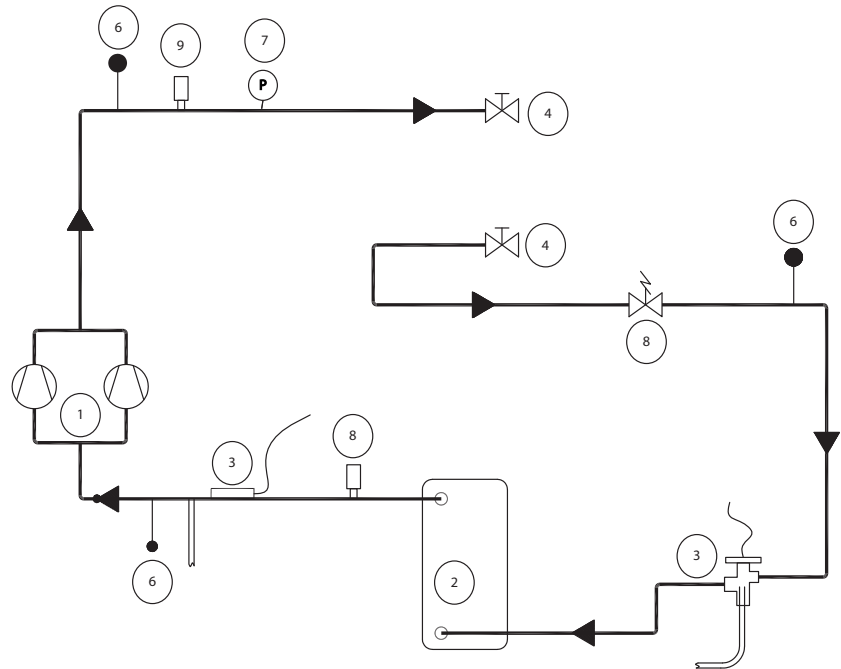

- 1: Compressor
- 2: Brazed plate evaporator
- 3: Expansion valve (Bulb+Balance port)
- 4: Stop valve
- 5: Solenoid valve
- 6: Schraeder
- 7: High pressure switch
- 8: Low pressure transducer
- 9: High pressure transducer

For additional information, contact :

The manufacturer has a policy of continuous product improvement, and reserves the right to alter any details of the products at any time without notice.

This publication is a general guide to install, use and properly maintain our products. The information given may be different from the specification for a particular country or for a specific order. In this event, please refer to your nearest office.

Distributor / Installer stamp



TRANE[®]

Cooling and Heating
Systems and Services



Quality Management
System Approval



Literature order number	CG-PRC008-E4
Date	0507
Supersedes	CG-PRC008-GB_0301, ACDS-PRC002-GB_0101
Stocking location	Europe

Trane has a policy of continuous product and product data improvement and reserves the right to change design and specifications without notice. Only qualified technicians should perform the installation and servicing of equipment referred to in this publication.

A business of American Standard Companies
www.trane.com

For more information, contact your local Trane district office or e-mail us at comfort@trane.com

American Standard Europe BVBA/SPRL
1789 Chaussée de Wavre, 1160 Brussels, Belgium
NE/ON: 0475 956 135 - RPM/RPR BRUXELLES/BRUSSEL